

M220 Series

EC Centrifugal Fan Ø220 x 97 mm



Impeller : Made of plastic ABS UL94 V-0

風 輪: ABS塑料制, 阻燃等级UL94 V-0

Frame : Made of die-cast Aluminum

外 框: 压铸铝合金

Motor : 8 Poles brushless DC motor

電 機: 8极无刷直流

Model (型号)	Bearing System (轴承)	Rated Voltage (电压) [VAC]	Voltage Range (电压范围) [VAC]	Freq. (频率) [Hz]	Input Power (功率) [W]	Speed (转速) [RPM]	Maximum Air Flow (风量) [CFM]	Maximum Air Flow (风量) [m³/h]	Max. Static Pressure (静压) [InH ₂ O]	Max. Static Pressure (静压) [Pa]	Niose Level (噪音) [dB-A]	Mass (质量) [g]
M220HE2	Ball	220	100~240	50/60	85	3000	487.1	828.5	2.668	664.4	74	1450

Air Flow & Static Pressure Curve

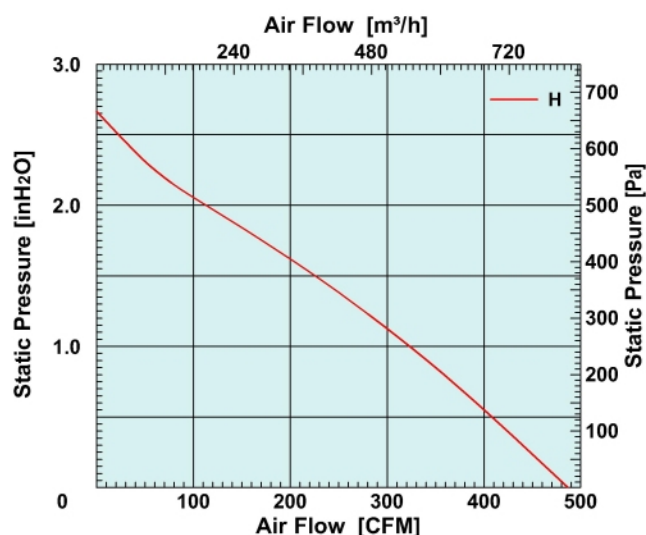

Dimensions Drawing

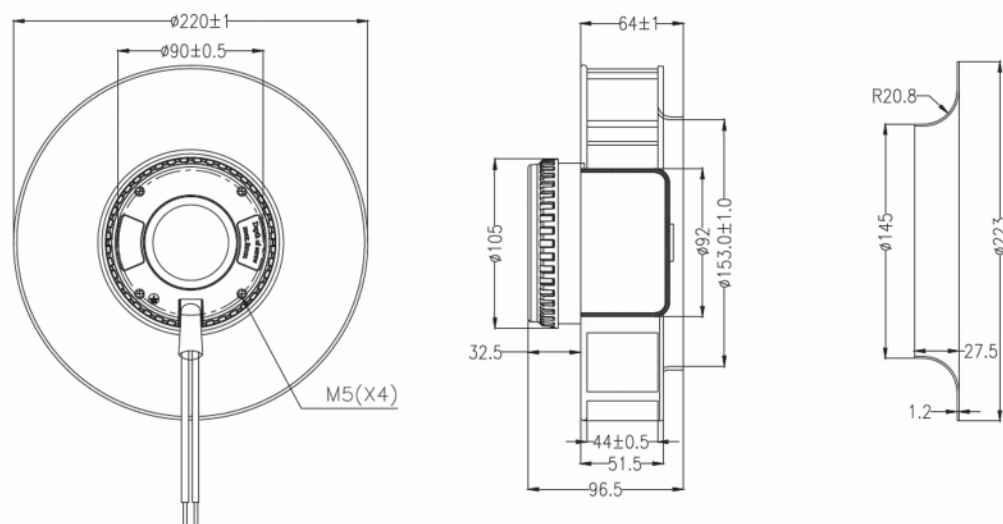

Above specification is only for reference and subject to change without notice.

以上数据仅供参考, 如有变更恕不另行通知。