

AUTO  
RESTART

PWM

FG

RD  
SIGNAL H

RD  
SIGNAL L

# DC Centrifugal Fan Ø133 x 80 mm

## M133 Series



Impeller : Made of plastic ABS UL94 V-0

風 輪: ABS塑料制, 阻燃等级 UL94 V-0

Frame : Made of die-cast Aluminum

外 框: 压铸铝合金

Motor : 8 Poles brushless DC motor

電 機: 8极无刷直流

Model (型号)	Bearing System (轴承)	Rated Voltage (电压) [V]	Voltage Range (电压范围) [V]	Current (电流) [A]	Speed (转速) [RPM]	Maximum Air Flow (风量) [CFM]	Maximum Air Flow (风量) [m³/h]	Max. Static Pressure (静压) [InH <sub>2</sub> O]	Max. Static Pressure (静压) [Pa]	Niose Level (噪音) [dB-A]	Mass (质量) [g]
M133LD2	Ball	24	18.0~26.5	0.90	2500	105.8	180	0.535	133.3	51.5	780
M133LD2	Ball	24	18.0~26.5	1.25	3300	139.7	240	0.93	231.4	57.5	790
M133MD2	Ball	24	18.0~26.5	2.6	4500	194.7	330	1.80	450	64.7	795
M133HD2	Ball	24	18.0~26.5	6.2	6200	264.8	450	3.29	818.6	71.0	800
M133LD4	Ball	48	36.0~54.0	0.52	3300	139.7	240	0.93	231.4	57.5	790
M133MD4	Ball	48	36.0~54.0	1.1	4500	194.7	330	1.80	450	64.7	796
M133HD4	Ball	48	36.0~54.0	2.5	5700	241.5	410	2.78	691.3	69.4	800



MUTUAL MOTOR

直流离心风机

www.mutualmotor.com

### Air Flow & Static Pressure Curve

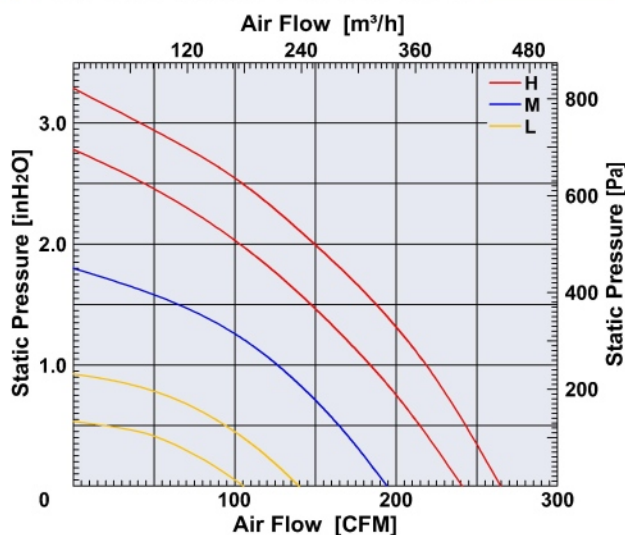

### Dimensions Drawing

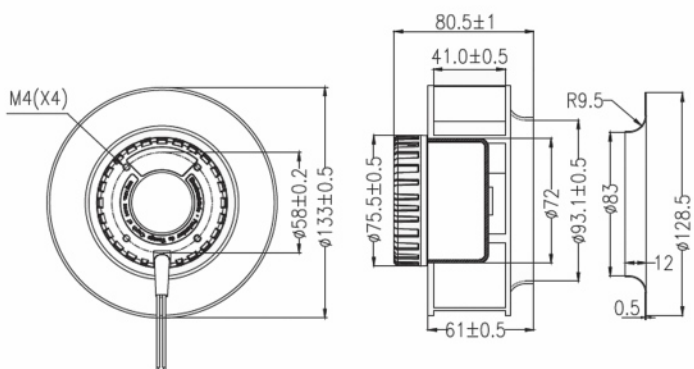

Above specification is only for reference and subject to change without notice.

以上数据仅供参考, 如有变更恕不另行通知。