

M20060 DC AXIAL FAN Series

□ 202x202x60mm

- AUTO (RESTAR)
- PWM
- FG
- RD SIGNAL H
- RD SIGNAL L



Impeller : 5 blades ,made of plastic PBT UL94 V-0

扇 叶: 5叶,PBT塑料制,阻燃等级UL94 V-0

Frame : Made of die-cast Aluminum ADC-12

扇 框: 压铸铝 ADC-12

Motor : 8 Poles brushless DC motor

電 機: 8极无刷直流

Model (型号)	Bearing System (轴承)	Rated Voltage (电压) [V]	Voltage Range (电压范围) [V]	Current (电流) [A]	Speed (转速) [RPM]	Maximum Air Flow (风量) [CFM]	Maximum Air Flow (风量) [m³/min]	Max. Static Pressure (静压) [inH ₂ O]	Max. Static Pressure (静压) [Pa]	Noise Level (噪音) [dB-A]	Mass (质量) [g]
M20060LD1	Ball	12	6.0~13.7	0.80	1500	308.2	8.72	0.22	54.8	52.0	2400
M20060LD2	Ball	24	18.0~26.7	0.38	1500	308.2	8.72	0.22	54.8	52.0	2400
M20060LD4	Ball	48	36.0~55.0	0.18	1500	308.2	8.72	0.22	54.8	52.0	2400
M20060MD1	Ball	12	6.0~13.7	1.65	2000	410.93	11.66	0.29	72.2	56.0	2400
M20060MD2	Ball	24	18.0~26.7	0.78	2000	410.93	11.66	0.29	72.2	56.0	2400
M20060MD4	Ball	48	36.0~55.0	0.37	2000	410.93	11.66	0.29	72.2	56.0	2400
M20060HD1	Ball	12	6.0~13.7	2.92	2500	513.66	14.57	0.36	89.6	60.0	2400
M20060HD2	Ball	24	18.0~26.7	1.39	2500	513.66	14.57	0.36	89.6	60.0	2400
M20060HD4	Ball	48	36.0~55.0	0.66	2500	513.66	14.57	0.36	89.6	60.0	2400
M20060VD1	Ball	12	6.0~13.7	4.73	3000	616.4	17.50	0.45	112.0	65.0	2400
M20060VD2	Ball	24	18.0~26.7	2.25	3000	616.4	17.50	0.45	112.0	65.0	2400
M20060VD4	Ball	48	36.0~55.0	1.07	3000	616.4	17.50	0.45	112.0	65.0	2400
M20060SD1	Ball	12	6.0~13.7	7.40	3500	720.0	20.40	0.51	127.0	70.0	2400
M20060SD2	Ball	24	18.0~26.7	3.52	3500	720.0	20.40	0.51	127.0	70.0	2400
M20060SD4	Ball	48	36.0~55.0	1.67	3500	720.0	20.40	0.51	127.0	70.0	2400

Dimensions Drawing

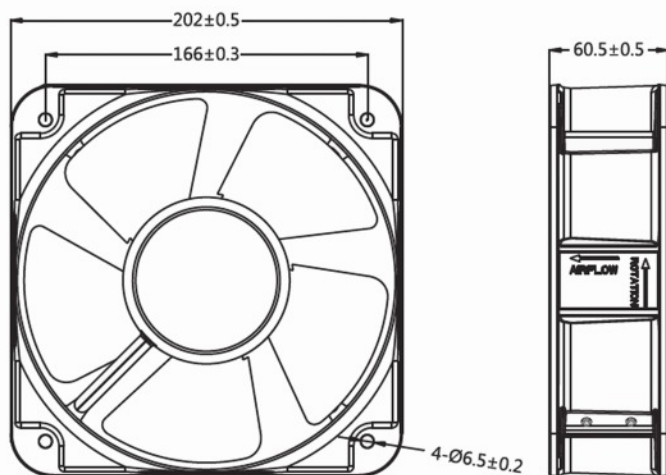

Air Flow & Static Pressure Curve

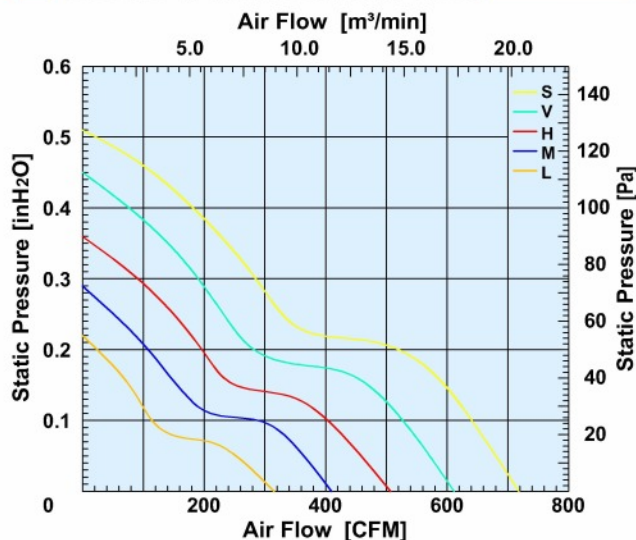

Above specification is only for reference and subject to change without notice.

以上数据仅供参考, 如有变更恕不另行通知。