

AUTO
RESTART

PWM

FG

RD
SIGNAL H

RD
SIGNAL L

DC AXIAL FAN

□ 50 x 50 x 10 mm

M5010
Series



Impeller : 7 blades ,made of plastic PBT UL94 V-0

扇 叶: 7叶,PBT塑料制,阻燃等级UL94 V-0

Frame : Made of plastic PBT UL94 V-0

扇 框: PBT塑料制,阻燃等级UL94 V-0

Motor : 4 Poles brushless DC motor

電 機: 4极无刷直流

Model (型号)	Bearing System (轴承)	Rated Voltage (电压) [V]	Voltage Range (电压范围) [V]	Current (电流) [A]	Speed (转速) [RPM]	Maximum Air Flow (风量) [CFM]	Maximum Air Flow (风量) [m³/min]	Max. Static Pressure (静压) [InH ₂ O]	Max. Static Pressure (静压) [Pa]	Niose Level (噪音) [dB-A]	Mass (质量) [g]
M5010LD0	B/S	5	3.6~6.8	0.13	4000	10.65	0.25	0.09	22.4	21.0	16.2
M5010LD1	B/S	12	6.0~13.5	0.07	4000	10.65	0.25	0.09	22.4	21.0	16.2
M5010MD0	B/S	5	3.6~6.8	0.17	5000	12.53	0.32	0.15	37.35	28.5	16.5
M5010MD1	B/S	12	6.0~13.5	0.10	5000	12.53	0.32	0.15	37.35	28.5	16.5
M5010HD0	B/S	5	3.6~6.8	0.23	6000	13.42	0.38	0.23	57.3	32.6	17
M5010HD1	B/S	12	6.0~13.5	0.14	6000	13.42	0.38	0.23	57.3	32.6	17
M5010HD2	B/S	24	18.0~26.5	0.08	6000	13.42	0.38	0.23	57.3	32.6	17
M5010VD0	B/S	5	3.6~6.8	0.47	6500	14.83	0.42	0.25	62.25	34.0	17
M5010VD1	B/S	12	6.0~13.5	0.22	6500	14.83	0.42	0.25	62.25	34.0	17
M5010VD2	B/S	24	18.0~26.5	0.12	6500	14.83	0.42	0.25	62.25	34.0	17

MUTUAL MOTOR

直流轴流风扇

www.mutualmotor.com

Air Flow & Static Pressure Curve

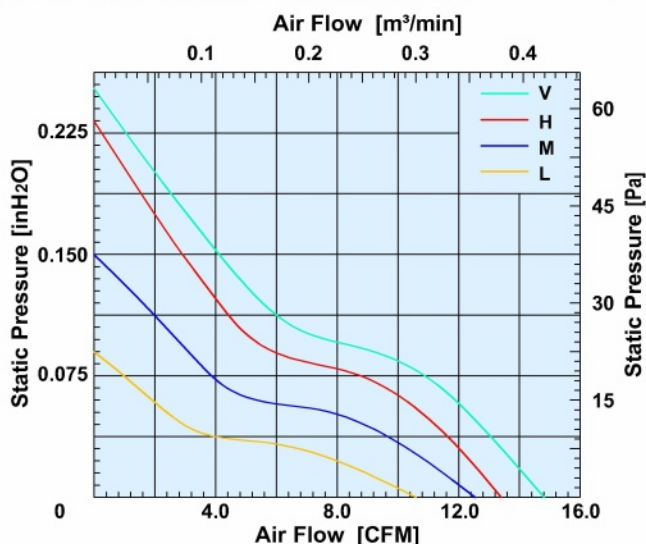

Dimensions Drawing

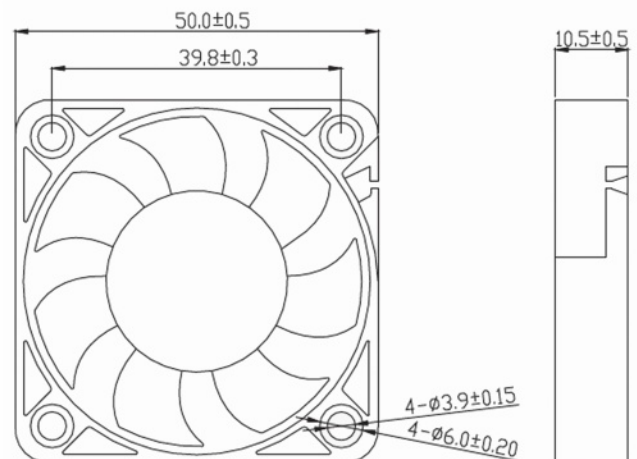

Above specification is only for reference and subject to change without notice.
以上数据仅供参考, 如有变更恕不另行通知。