

M195K Series

AC AXIAL FAN
□ 205x205x72mm



Impeller : 5 blades ,made of PBT resin

扇 叶: 5叶 PBT塑料

Frame : Made of die-cast Aluminum ADC-12

扇 框: 压铸铝 ADC-12

Motor : Capacitor-run induction motor

電 機: 电容运转异步电机

Motor Protection : Thermal protection

电机保护: 热保护

Model (型号)	Bearing System (轴承)	Rated Voltage (电压) [V]	Freq. (频率) [Hz]	Current (电流) [A]	Input power (功率) [W]	Speed (转速) [RPM]	Maximum Air Flow (风量) [CFM]	Maximum Air Flow (风量) [m³/min]	Max. Static Pressure (静压) [InchH ₂ O]	Max. Static Pressure (静压) [Pa]	Noise Level (噪音) [dB-A]	Mass (质量) [g]
M195KA1H	Ball	115	50/60	0.62/0.88	70/100	2800/3200	600/665	17.0/18.3	0.98/0.85	239/212	67/71	2100
M195KA2H	Ball	230	50/60	0.32/0.45	70/100	2800/3200	600/665	17.0/18.3	0.98/0.85	239/212	67/71	2100
M195KA3H	Ball	380	50/60	0.18/0.26	68/98	2800/3200	600/665	17.0/18.3	0.98/0.85	239/212	67/71	2100
M195KA3ØH	Ball	380	50/60	0.18/0.26	68/98	2800/3200	600/665	17.0/18.3	0.98/0.85	239/212	67/71	2100

Dimensions Drawing

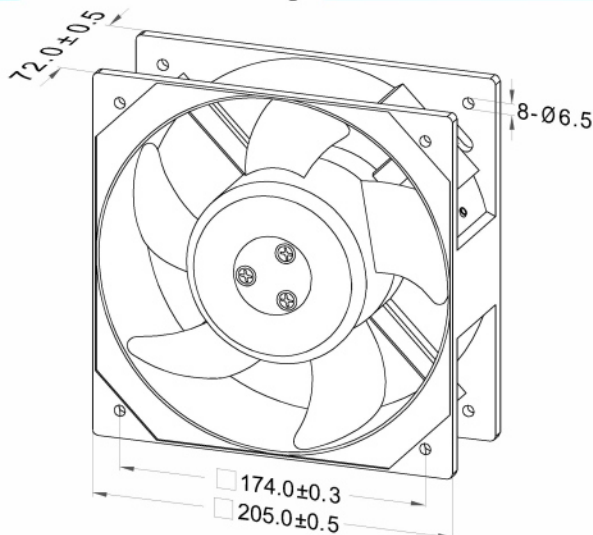

Air Flow & Static Pressure Curve

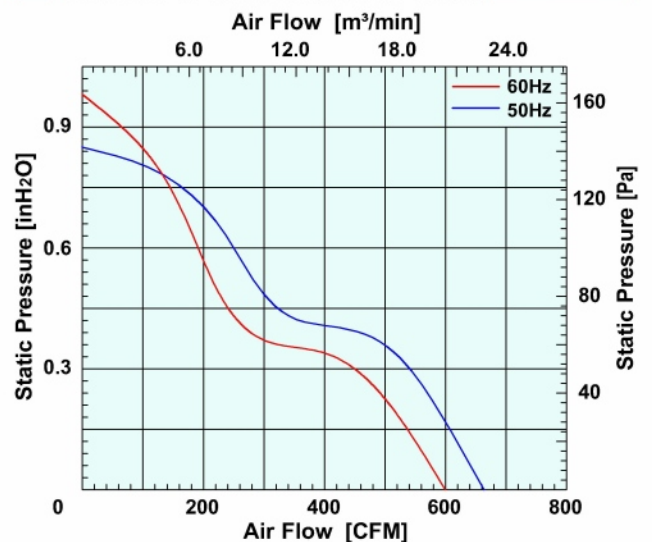

Above specification is only for reference and subject to change without notice.

以上数据仅供参考，如有变更恕不另行通知。