

定制品

AC Centrifugal Fan 交流后倾式离心风机

ALL
Series



MUTUAL MOTOR

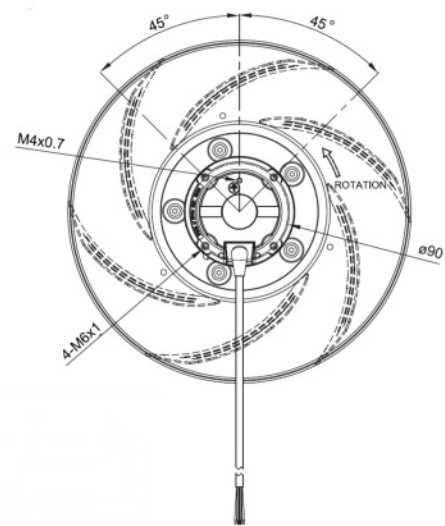
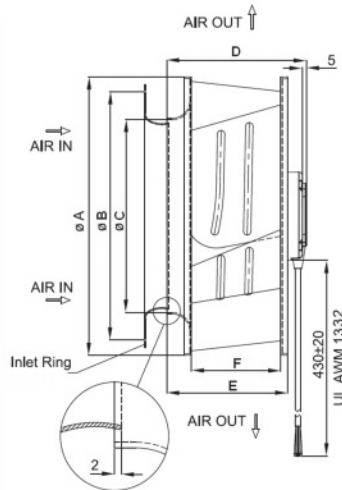

Impeller : Made of Aluminum

風輪: 铝

Frame : Made of Die-cast Aluminum

外框: 压铸铝

Motor : External rotor & Capacitor-run induction motor

電機: 外转子电容运转异步電機

Unit:mm

型号	尺寸	A	B	C	D	E	F
M320-A		320	340	220	128	108	70
M320-B		320	340	220	160	140	100
M355		355	360	250	160	147	96
M400-A		400	344	264	171	140	89
M400-B		400	344	264	218	188	140

Model (型号)	Bearing System (轴承)	Rated Voltage (电压) [V]	Freq. (频率) [Hz]	Current (电流) [A]	Input power (功率) [W]	Speed (转速) [RPM]	Maximum Air Flow (风量) [CFM]	Maximum Air Flow (风量) [m³/h]	Max. Static Pressure (静压) [InchH ₂ O]	Max. Static Pressure (静压) [Pa]	Niose Level (噪音) [dB-A]	Mass (质量) [g]
M320HA2-A	Ball	230	50	0.69	120	1600	1148	1950	1.6	400	66	3600
M320HA3Ø-A	Ball	380	50	0.23	100	1400	995	1690	1.4	350	62	3600
M320HA1-B	Ball	115	60	1.50	162	1600	1402	2380	1.8	450	78	3850
M320HA2-B	Ball	230	50	0.60	135	1400	1254	2130	1.4	350	75	3850
M320HA3Ø-B	Ball	380	50	0.45	134	1400	1254	2130	1.4	350	75	3850
M355HA1	Ball	115	60	2.30	240	1550	1731	2940	2.2	550	69	4700
M355HA2	Ball	230	50	0.90	195	1350	1519	2580	1.6	400	66	4700
M355HA3	Ball	380	50	0.50	178	1350	1519	2580	1.6	400	66	4700
M355HA3Ø	Ball	380	50	0.46	170	1350	1519	2580	1.6	400	66	4700
M400HA2-A	Ball	230	50	1.2	260	1300	1855	3150	2.0	500	73	5650
M400HA3-A	Ball	380	50	0.69	250	1300	1855	3150	2.0	500	70	5650
M400HA2-B	Ball	230	50	1.20	275	1350	2355	4000	1.767	440	68	7000
M400HA3-B	Ball	380	50	0.65	160	1350	2355	4000	1.767	440	68	7000

Above specification is only for reference and subject to change without notice.

以上数据仅供参考，如有变更恕不另行通知。

交流离心風機

www.mutualmotor.com