

M7530 Series

DC BLOWER  
75 x 75 x 30 mm

AUTO  
RESTART

PWM

FG

RD  
SIGNAL H

RD  
SIGNAL L



Impeller : Made of plastic PBT UL94 V-0

風 輪: PBT塑料制, 阻燃等级UL94 V-0

Frame : Made of plastic PBT UL94 V-0

扇 框: PBT塑料制, 阻燃等级UL94 V-0

Motor : 4 Poles brushless DC motor

電 機: 4极无刷直流

Model (型号)	Bearing System (轴承)	Rated Voltage (电压) [V]	Voltage Range (电压范围) [V]	Current (电流) [A]	Speed (转速) [RPM]	Maximum Air Flow (风量) [CFM]	Maximum Air Flow (风量) [m³/min]	Max. Static Pressure (静压) [InH <sub>2</sub> O]	Max. Static Pressure (静压) [Pa]	Noise Level (噪音) [dB-A]	Mass (质量) [g]
M7530LD1	B/S	12	6.0~13.5	0.12	2000	6.31	0.18	0.2	49.8	32	75
M7530LD2	B/S	24	18.0~26.5	0.08	2000	6.31	0.18	0.2	49.8	32	75
M7530MD1	B/S	12	6.0~13.5	0.23	2500	8.34	0.24	0.26	74.7	37	76
M7530MD2	B/S	24	18.0~26.5	0.11	2500	8.34	0.24	0.26	74.7	37	76
M7530HD1	B/S	12	6.0~13.5	0.28	3000	10.35	0.29	0.38	94.6	41.5	78
M7530HD2	B/S	24	18.0~26.5	0.14	3000	10.35	0.29	0.38	94.6	41.5	78
M7530HD2	B/S	48	36.0~54.0	0.07	3000	10.35	0.29	0.38	94.6	41.5	78
M7530VD1	B/S	12	6.0~13.5	0.35	3400	11.0	0.31	0.50	124.5	43	78.5
M7530VD2	B/S	24	18.0~26.5	0.20	3400	11.0	0.31	0.50	124.5	43	78.5
M7530VD2	B/S	48	36.0~54.0	0.09	3400	11.0	0.31	0.50	124.5	43	78.5
M7530SD1	B/S	24	18.0~26.5	0.30	3700	12.66	0.36	0.64	159.4	46	78.5
M7530SD2	B/S	48	36.0~54.0	0.14	3700	12.66	0.36	0.64	159.4	46	78.5

### Dimensions Drawing

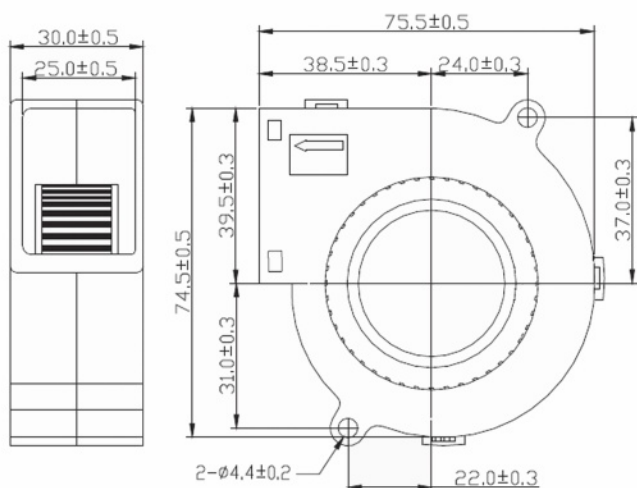

### Air Flow and Static Pressure

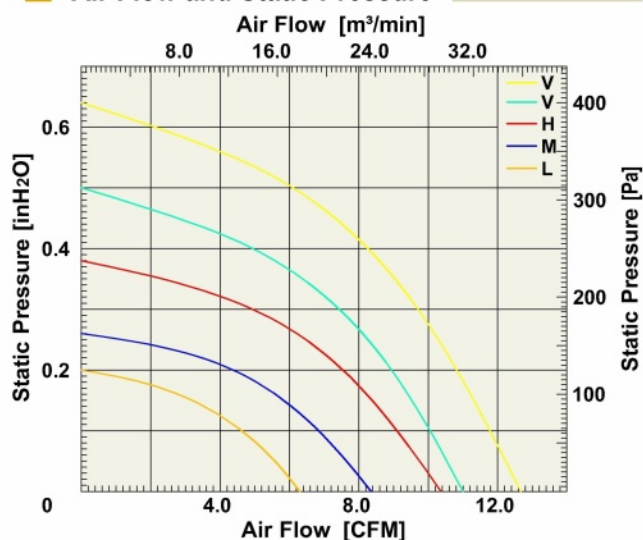

Above specification is only for reference and subject to change without notice.

以上数据仅供参考, 如有变更恕不另行通知。