

M22580 EC AXIAL FAN Series

□ 225x225x80mm

AUTO
RESTAR

PWM

FG

RD
SIGNAL H

RD
SIGNAL L



Impeller : 9 blades ,made of steel

扇 叶: 9叶, 钢制

Frame : Made of Aluminum die-casting ADC-12

扇 框: 压铸铝 ADC-12

Motor : 6 Poles brushless DC motor

電 機: 6极无刷直流

Model (型号)	Bearing System (轴承)	Rated Voltage (电压) [VAC]	Voltage Range (电压范围) [VAC]	Freq. (频率) [Hz]	Input Power (功率) [W]	Speed (转速) [RPM]	Maximum Air Flow (风量) [CFM]	Maximum Air Flow (风量) [m³/min]	Max. Static Pressure (静压) [InH₂O]	Max. Static Pressure (静压) [Pa]	Niose Level (噪音) [dB-A]	Mass (质量) [g]
M22580HE1	Ball	110	80~130	50/60	60	2900	600	17.0	1.01	251.5	62	2500
M22580HE2	Ball	220	100~240	50/60	60	2900	600	17.0	1.01	251.5	62	2500

Dimensions Drawing

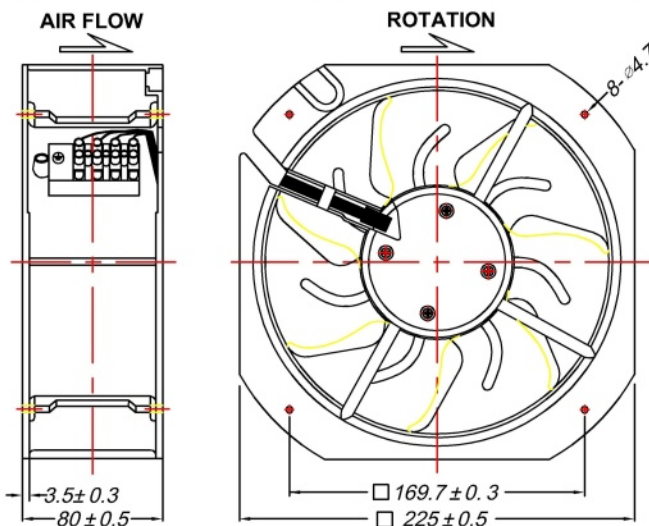

Air Flow and Static Pressure

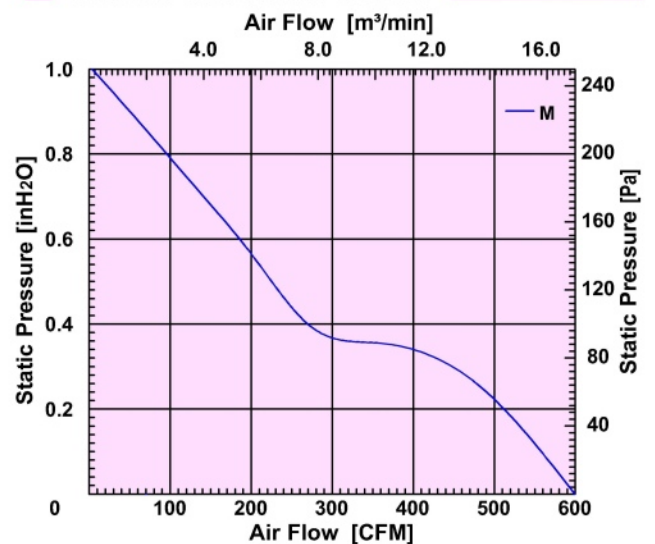

Above specification is only for reference and subject to change without notice.

以上数据仅供参考，如有变更恕不另行通知。