

M17150 EC AXIAL FAN Series

Ø171 x 51 mm

- AUTO (RESTAR)
- PWM
- FG
- RD SIGNAL H
- RD SIGNAL L

Impeller : 3 blades ,made of plastic PBT UL94 V-0

扇叶: 7叶, PBT塑料制, 阻燃等级UL94 V-0

Frame : Made of Aluminum die-casting ADC-12

扇框: 压铸铝 ADC-12

Motor : 8 Poles brushless DC motor

电机: 8极无刷直流



Model (型号)	Bearing System (轴承)	Rated Voltage (电压) [VAC]	Voltage Range (电压范围) [VAC]	Freq. (频率) [Hz]	Input Power (功率) [W]	Speed (转速) [RPM]	Maximum Air Flow (风量) [CFM]	Maximum Air Flow (风量) [m³/min]	Max. Static Pressure (静压) [inH2O]	Max. Static Pressure (静压) [Pa]	Niose Level (噪音) [dB-A]	Mass (质量) [g]
M17150LE1	Ball	110	80~130	50/60	5.5	2000	145.7	4.25	0.31	77.2	46.9	672
M17150LE2	Ball	220	100~240	50/60	5.5	2000	145.7	4.25	0.31	77.2	46.9	672
M17150ME1	Ball	110	80~130	50/60	18	3000	223.9	6.34	0.63	156.9	53	675
M17150ME2	Ball	220	100~240	50/60	16	3000	223.9	6.34	0.63	156.9	53	675
M17150HE1	Ball	110	80~130	50/60	38	4000	286.6	8.12	1.1	273.9	54.5	678
M17150HE2	Ball	220	100~240	50/60	35	4000	286.6	8.12	1.1	273.9	54.5	678
M17150VE1	Ball	110	80~130	50/60	70	5000	358.3	10.15	1.38	343.6	68.4	680
M17150VE2	Ball	220	100~240	50/60	65	5000	358.3	10.15	1.38	343.6	68.4	680

Dimensions Drawing

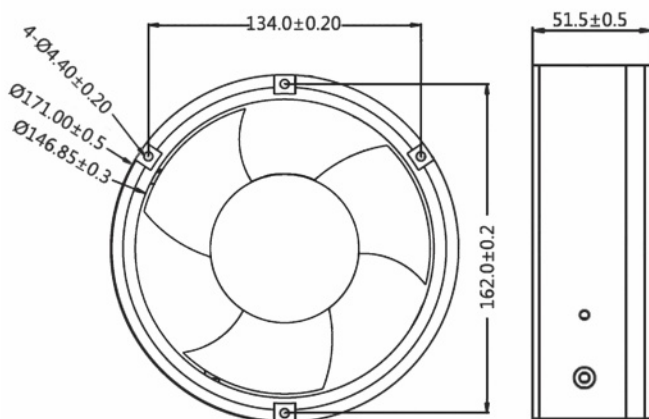

Air Flow and Static Pressure

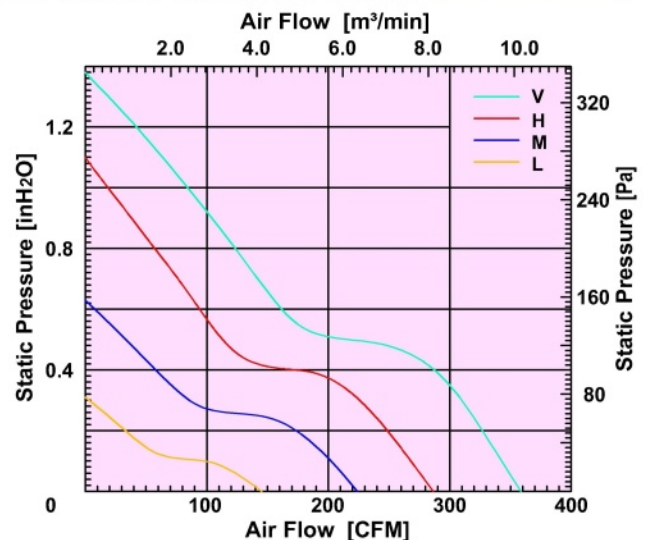

Above specification is only for reference and subject to change without notice.

以上数据仅供参考, 如有变更恕不另行通知。