

AUTO
RESTAR

PWM

FG

RD
SIGNAL H

RD
SIGNAL L

DC AXIAL FAN M17150 Series

Ø171 x 51 mm



Impeller : 7 blades ,made of plastic PBT UL94 V-0

扇 叶: 7叶,PBT塑料制,阻燃等级UL94 V-0

Frame : Made of Aluminum die-casting ADC-12

扇 框: 压铸铝 ADC-12

Motor : 8 Poles brushless DC motor

電 機: 8极无刷直流

Model (型号)	Bearing System (轴承)	Rated Voltage (电压) [V]	Voltage Range (电压范围) [V]	Current (电流) [A]	Speed (转速) [RPM]	Maximum Air Flow (风量) [CFM]	Maximum Air Flow (风量) [m³/min]	Max. Static Pressure (静压) [InH2O]	Max. Static Pressure (静压) [Pa]	Niose Level (噪音) [dB-A]	Mass (质量) [g]
M17150LD1	B	12	6.0~13.5	0.85	2000	187.4	5.31	0.28	70.4	51.3	685
M17150LD2	B	24	18.0~26.5	0.3	2000	187.4	5.31	0.28	70.4	51.3	685
M17150LD4	B	48	36.0~54.0	0.16	2000	187.4	5.31	0.28	70.4	51.3	685
M17150MD1	B	12	6.0~13.5	1.70	2500	238.8	6.77	0.42	104.7	54.5	690
M17150MD2	B	24	18.0~26.5	0.75	2500	238.8	6.77	0.42	104.7	54.5	690
M17150MD4	B	48	36.0~54.0	0.40	2500	238.8	6.77	0.42	104.7	54.5	690
M17150HD1	B	12	6.0~13.5	2.6	3000	280	7.93	0.478	119	59.5	694
M17150HD2	B	24	18.0~26.5	1.3	3000	280	7.93	0.478	119	59.5	694
M17150HD4	B	48	36.0~54.0	0.65	3000	280	7.93	0.478	119	59.5	694

PS.高转数据参考M17251--7叶

MUTUAL MOTOR

直流轴流風扇

Air Flow and Static Pressure

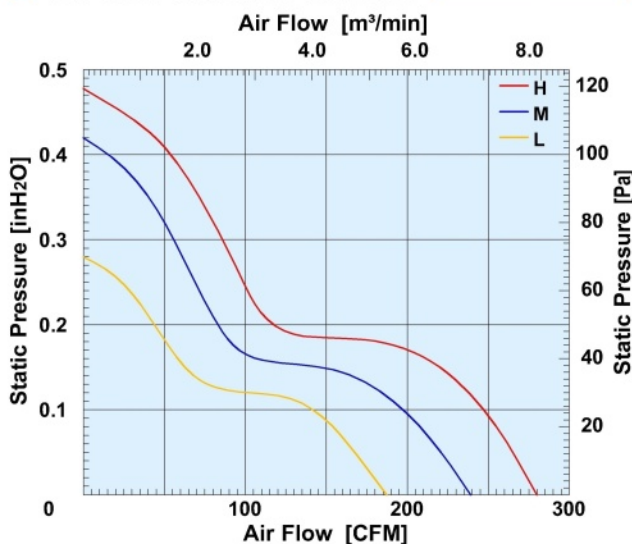

Dimensions Drawing

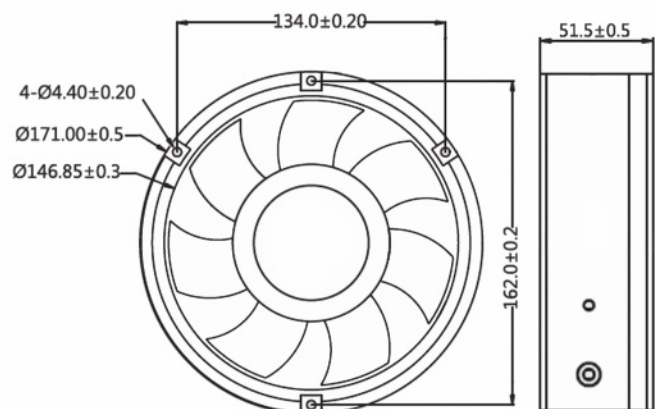

Above specification is only for reference and subject to change without notice.

以上数据仅供参考, 如有变更恕不另行通知。

www.mutualmotor.com