

AUTO
RESTAR

PWM

FG

RD
SIGNAL H

RD
SIGNAL L

DC AXIAL FAN

M25489

∅254 x 89 mm

Series



Impeller : 3 blades ,made of plastic PBT UL94 V-0

扇 叶: 3叶,PBT塑料制, 阻燃等级UL94 V-0

Frame : Made of Aluminum die-casting ADC-12

扇 框: 压铸铝 ADC-12

Motor : 8 Poles brushless DC motor

電 機: 8极无刷直流

Model (型号)	Bearing System (轴承)	Rated Voltage (电压) [V]	Voltage Range (电压范围) [V]	Current (电流) [A]	Speed (转速) [RPM]	Maximum Air Flow (风量) [CFM]	Maximum Air Flow (风量) [m³/min]	Max. Static Pressure (静压) [InH2O]	Max. Static Pressure (静压) [Pa]	Niose Level (噪音) [dB-A]	Mass (质量) [g]
M25489LD1	Ball	12	6.0~13.5	0.75	1000	308	8.72	0.49	122	51	2600
M25489LD2	Ball	24	18.0~26.5	0.5	1000	308	8.72	0.49	122	51	2600
M25489LD4	Ball	48	36.0~54.0	0.2	1000	308	8.72	0.49	122	51	2600
M25489MD1	Ball	12	6.0~13.5	3.5	2000	565	16.0	0.65	162	62	2600
M25489MD2	Ball	24	18.0~26.5	1.5	2000	565	16.0	0.65	162	62	2600
M25489MD4	Ball	48	36.0~54.0	0.8	2000	565	16.0	0.65	162	62	2600
M25489HD2	Ball	24	18.0~26.5	3.7	3000	864	24.5	1.36	338.6	73.5	2600
M25489HD4	Ball	48	36.0~54.0	1.9	3000	864	24.5	1.36	338.6	73.5	2600
M25489VD2	Ball	24	18.0~26.5	7.8	4000	1321	37.4	1.70	423.3	90	2600
M25489VD4	Ball	48	36.0~54.0	4.0	4000	1321	37.4	1.70	423.3	90	2600



MUTUAL MOTOR

直流軸流風扇

www.mutualmotor.com

Air Flow and Static Pressure

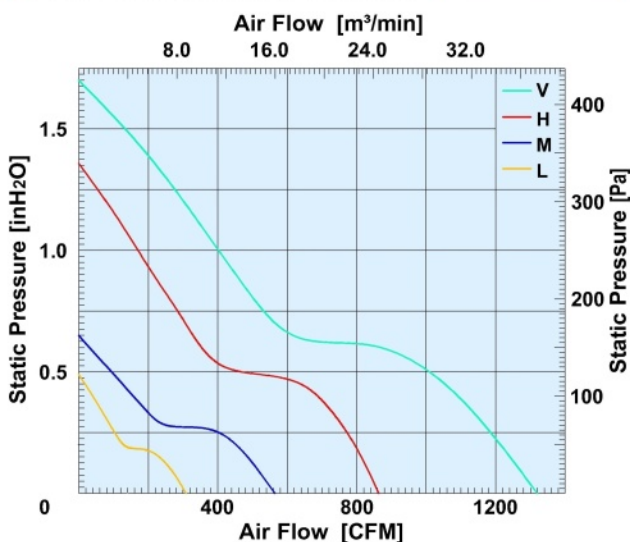

Dimensions Drawing

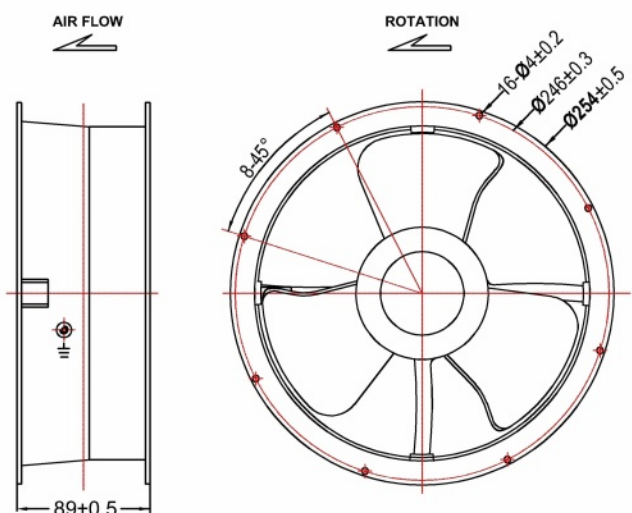

Above specification is only for reference and subject to change without notice.

以上数据仅供参考, 如有变更恕不另行通知。