

M3007 DC AXIAL FAN Series

□ 30 x 30 x 7 mm



Impeller : 7 blades ,made of plastic PBT UL94 V-0

扇 叶: 7叶,PBT塑料制, 阻燃等级UL94 V-0

Frame : Made of plastic PBT UL94 V-0

扇 框: PBT塑料制, 阻燃等级UL94 V-0

Motor : 4 Poles brushless DC motor

電 機: 4极无刷直流

Model (型号)	Bearing System (轴承)	Rated Voltage (电压) [V]	Voltage Range (电压范围) [V]	Current (电流) [A]	Speed (转速) [RPM]	Maximum Air Flow (风量) [CFM]	Maximum Air Flow (风量) [m³/min]	Max. Static Pressure (静压) [InH ₂ O]	Max. Static Pressure (静压) [Pa]	Niose Level (噪音) [dB-A]	Mass (质量) [g]
M3007LD0	B/S	5	3.6~6.8	0.12	5000	1.79	0.05	0.051	12.7	22.5	6.2
M3007LD1	B/S	12	6.0~13.5	0.04	5000	1.79	0.05	0.051	12.7	22.5	6.2
M3007MD0	B/S	5	3.6~6.8	0.17	8000	2.86	0.08	0.075	18.7	28.6	6.2
M3007MD1	B/S	12	6.0~13.5	0.06	8000	2.86	0.08	0.075	18.7	28.6	6.2
M3007HD0	B/S	5	3.6~6.8	0.25	11000	3.92	0.11	0.114	28.4	32.6	6.3
M3007HD1	B/S	12	6.0~13.5	0.10	11000	3.92	0.11	0.114	28.4	32.6	6.3
M3007VD0	B/S	5	3.6~6.8	0.32	13000	4.25	0.12	0.141	35.1	36.8	6.3
M3007VD1	B/S	12	6.0~13.5	0.12	13000	4.25	0.12	0.141	35.1	36.8	6.3

Dimensions Drawing

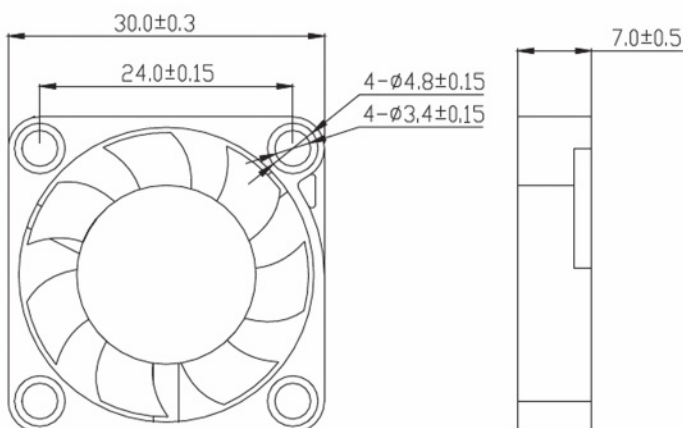

Air Flow and Static Pressure

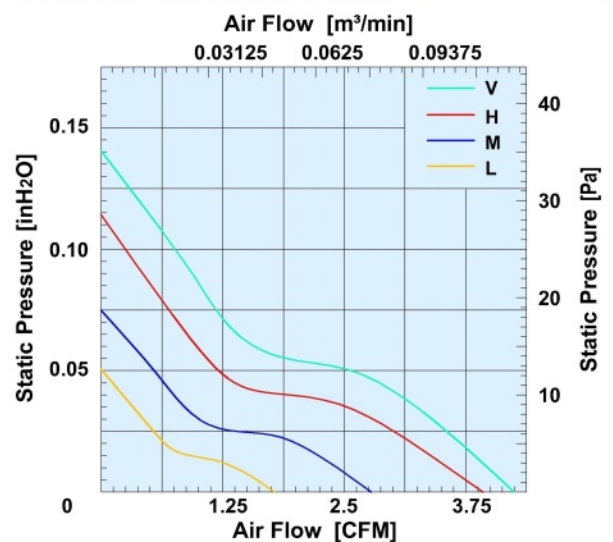

Above specification is only for reference and subject to change without notice.

以上数据仅供参考, 如有变更恕不另行通知。