

M115B Series

AC AXIAL FAN

□ 120x120x38mm



Impeller : 5 blades ,made of PBT resin

扇 叶: 5叶 PBT塑料

Frame : Made of die-cast Aluminum ADC-12

扇 框: 压铸铝 ADC-12

Motor : Shaded pole induction motor

電 機: 蔽極异步電機

Motor Protection : Impedance protection

電機保护: 阻抗保护

Model (型号)	Bearing System (轴承)	Rated Voltage (电压) [V]	Freq. (频率) [Hz]	Current (电流) [A]	Input power (功率) [W]	Speed (转速) [RPM]	Maximum Air Flow (风量) [CFM]	Maximum Air Flow (风量) [m³/min]	Max. Static Pressure (静压) [InchH ₂ O]	Max. Static Pressure (静压) [Pa]	Niose Level (噪音) [dB-A]	Mass (质量) [g]
M115BA1H	B/S	115	50/60	0.27/0.21	25/19	2600/3000	87/103	2.5/2.9	0.28/0.34	70/85	43/49	520
M115BA2H	B/S	230	50/60	0.13/0.09	22/15	2600/3000	87/103	2.5/2.9	0.28/0.34	70/85	43/49	520
M115BA1M	B/S	115	50/60	0.17/0.13	14/10	2500/2800	82/95	2.3/2.7	0.18/0.24	45/60	39/44	520
M115BA2M	B/S	230	50/60	0.08/0.06	16/11	2500/2800	82/95	2.3/2.7	0.18/0.24	45/60	39/44	520
M115BA1L	B/S	115	50/60	0.12/0.10	11/9	1900/2400	65/78	1.84/2.21	0.10/0.13	25/32	34/39	520
M115BA2L	B/S	230	50/60	0.06/0.05	12/10	1900/2400	65/78	1.84/2.21	0.10/0.13	25/32	34/39	520
M115BA1X	B/S	115	50/60	0.30/0.24	28/21	2800/3150	97/113	2.75/3.2	0.34/0.39	75/90	43/50	520
M115BA3H	B/S	380	50/60	0.06/0.05	16/14	2600/3000	87/103	2.5/2.9	0.28/0.34	70/85	43/49	520

Dimensions Drawing

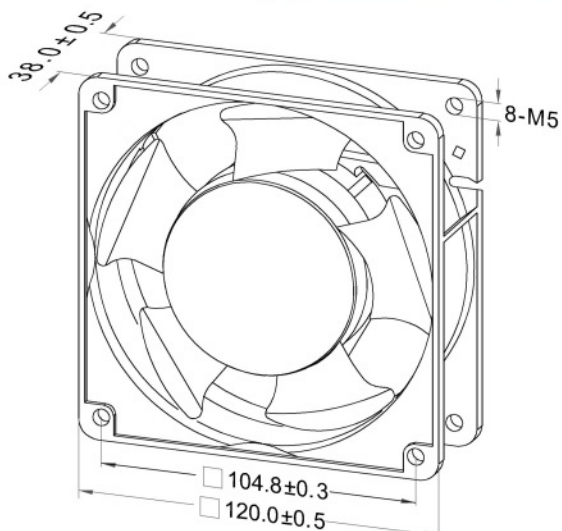

Air Flow & Static Pressure Curve

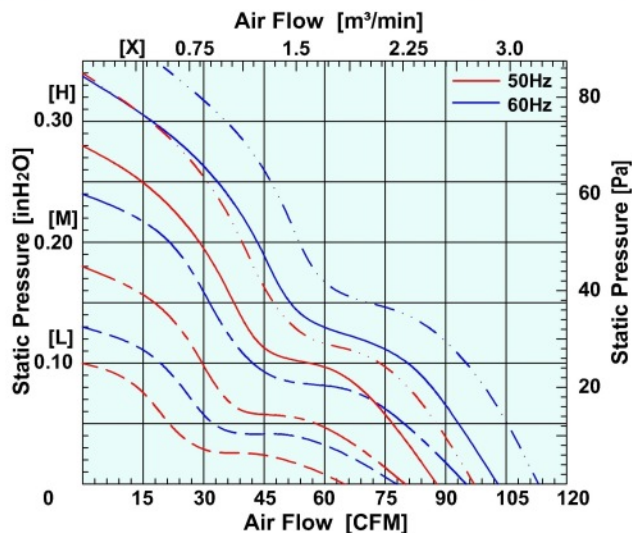

Above specification is only for reference and subject to change without notice.

以上数据仅供参考，如有变更恕不另行通知。