

# M230RF Series

# AC AXIAL FAN

Ø254 x 89 mm



Impeller : 3 blades ,made of PBT resin

扇 叶: 3叶 PBT塑料

Frame : Made of die-cast Aluminum ADC-12

扇 框: 压铸铝 ADC-12

Motor : External rotor & capacitor-run induction motor

電 機: 外转子电容运转异步電機

Motor Protection : Thermal protection

電機保护: 热保护

Model (型号)	Bearing System (轴承)	Rated Voltage (电压) [V]	Freq. (频率) [Hz]	Current (电流) [A]	Input power (功率) [W]	Speed (转速) [RPM]	Maximum Air Flow (风量) [CFM]	Maximum Air Flow (风量) [m³/min]	Max. Static Pressure (静压) [InchH₂O]	Max. Static Pressure (静压) [Pa]	Niose Level (噪音) [dB-A]	Mass (质量) [g]
M230RFA1H	Ball	115	50/60	0.74/0.94	84/105	2350/2400	750/795	21.2/22.5	0.71/0.56	172/140	64/67	2200
M230RFA2H	Ball	230	50/60	0.57/0.61	125/140	2550/2900	810/880	23.0/25.0	0.75/0.61	187/152	65/68	2200
M230RFA1L	Ball	115	50/60	0.45/0.58	50/65	1450/1650	460/550	13.0/15.5	0.32/0.40	80/100	52/54	2200
M230RFA2L	Ball	230	50/60	0.34/0.36	75/80	1450/1650	460/550	13.0/15.5	0.32/0.40	80/100	52/54	2200

## Dimensions Drawing

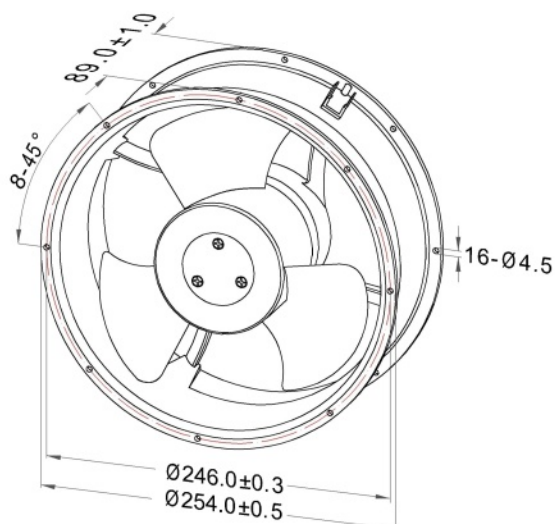

## Air Flow & Static Pressure Curve

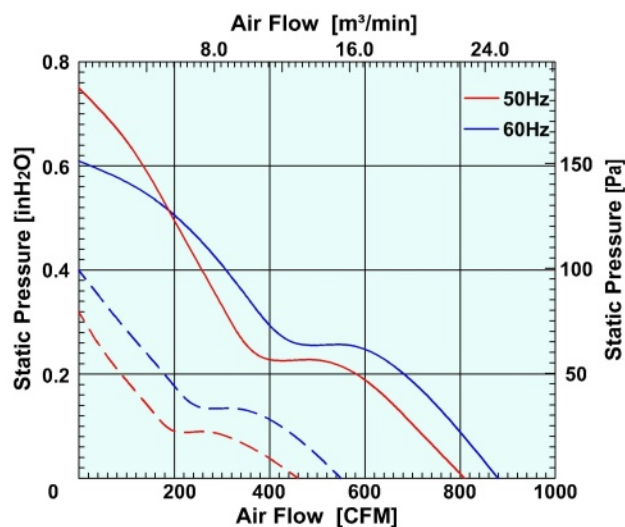

Above specification is only for reference and subject to change without notice.

以上数据仅供参考，如有变更恕不另行通知。