



Impeller : 7 blades ,made of PBT resin

扇 叶: 7叶 PBT塑料

Frame : Made of die-cast Aluminum ADC-12

扇 框: 压铸铝 ADC-12

Motor : Capacitor-run induction motor

電 機: 电容运转异步電機

Motor Protection : Thermal protection

電機保护: 热保护

Model (型号)	Bearing System (轴承)	Rated Voltage (电压) [V]	Freq. (频率) [Hz]	Current (电流) [A]	Input power (功率) [W]	Speed (转速) [RPM]	Maximum Air Flow (风量) [CFM]	Maximum Air Flow (风量) [m³/min]	Max. Static Pressure (静压) [InchH ₂ O]	Max. Static Pressure (静压) [Pa]	Noise Level (噪音) [dB-A]	Mass (质量) [g]
M150CA2H	Ball	230	50	0.19	40.0	2600	225	6.37	0.45	112	65	870
M150CA3H	Ball	380	50	0.10	38.0	2600	225	6.37	0.45	112	65	870

Air Flow & Static Pressure Curve

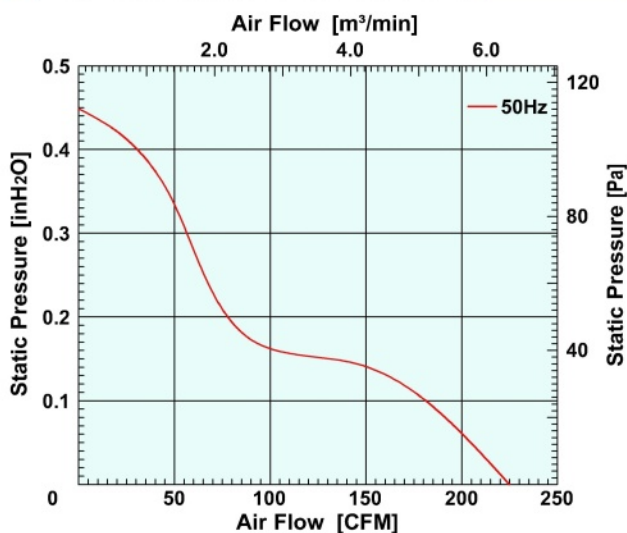

Dimensions Drawing

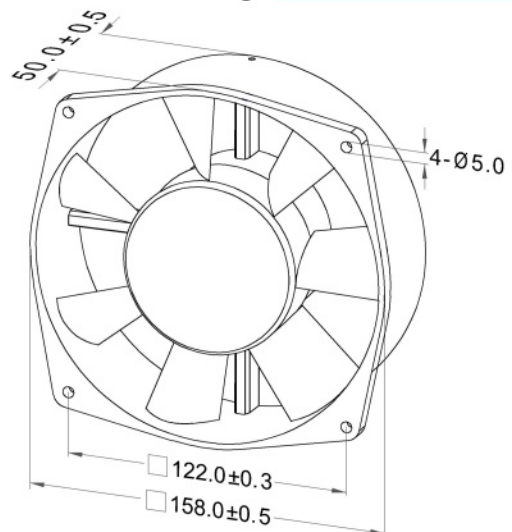

Above specification is only for reference and subject to change without notice.

以上数据仅供参考，如有变更恕不另行通知。