

M115A Series

AC AXIAL FAN

120x120x25mm



Impeller : 7 blades ,made of PBT resin

扇 叶: 7叶 PBT塑料

Frame : Made of die-cast Aluminum ADC-12

扇 框: 压铸铝 ADC-12

Motor : Shaded pole induction motor

電 機: 蔽極异步電機

Motor Protection : Impedance protection

電機保护: 阻抗保护

Model (型号)	Bearing System (轴承)	Rated Voltage (电压) [V]	Freq. (频率) [Hz]	Current (电流) [A]	Input power (功率) [W]	Speed (转速) [RPM]	Maximum Air Flow (风量) [CFM]	Maximum Air Flow (风量) [m³/min]	Max. Static Pressure (静压) [InchH ₂ O]	Max. Static Pressure (静压) [Pa]	Noise Level (噪音) [dB-A]	Mass (质量) [g]
M115AA1H	B/S	115	50/60	0.18/0.13	18/11	2300/2700	68/76	1.93/2.18	0.21/0.24	52/60	40/44	340
M115AA2H	B/S	230	50/60	0.09/0.07	16/14	2300/2700	68/76	1.93/2.18	0.21/0.24	52/60	40/44	340
M115AA1L	B/S	115	50/60	0.11/0.08	10/7	2000/2300	50/60	1.55/1.7	0.12/0.15	30/37	32/37	340
M115AA2L	B/S	230	50/60	0.06/0.05	13/9	2000/2300	50/60	1.55/1.7	0.12/0.15	30/37	32/37	340

Dimensions Drawing

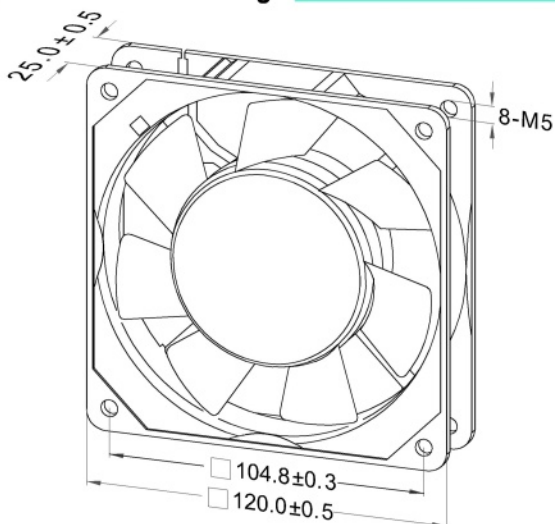

Air Flow & Static Pressure Curve

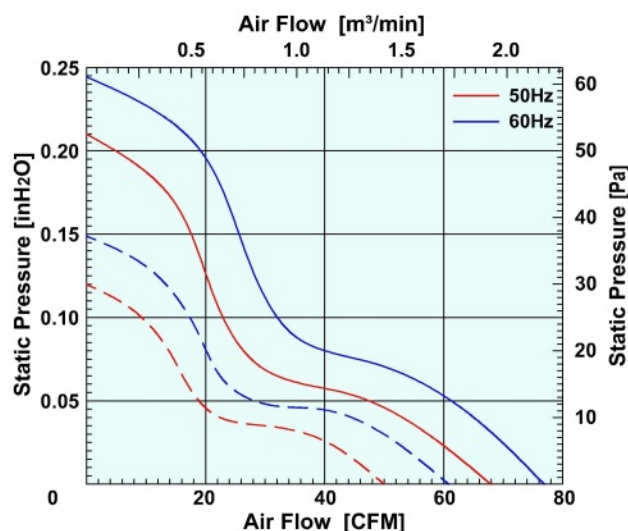

Above specification is only for reference and subject to change without notice.

以上数据仅供参考，如有变更恕不另行通知。